



Service Bulletin

American Honda Motor Co., Inc.

SAFETY RECALL

2001-2002 GL1800/A Frame Weld Inspection

(This supersedes GL1800/A #17, dated February 2005)

American Honda is conducting a Safety Recall on affected 2001-2002 GL1800/A Gold Wings to inspect frame welds.

Certain frame welds may not have sufficient strength. High loads created when riding on rough road surfaces or through potholes can cause the affected welds to crack. In the worst case, the welded area could break without warning, resulting in lower cross member separation and rear suspension collapse. This could result in a crash.

All affected units will have their frames inspected and, if necessary, repaired.

AFFECTED UNITS

All 2001 GL1800 (non-ABS)

1HFSC470*1A000010 thru 1HFSC470*1A006709

All 2001 GL1800A (ABS)

1HFSC474*1A000034 thru 1HFSC474*1A002553

2002 GL1800 (non-ABS)

1HFSC470*2A100001 thru 1HFSC470*2A111802

2002 GL1800A (ABS)

1HFSC474*2A100001 thru 1HFSC474*2A102393

NOTE: Trikes and vehicles with sidecars attached are excluded from this Safety Recall.

(*) Denotes check digit.

CUSTOMER NOTIFICATION

American Honda is sending a letter to owners of all affected 2001-2002 GL1800/A models, advising them to take their motorcycle to a Honda motorcycle dealer to have the Safety Recall procedure performed.

Your assistance is needed to ensure your GL1800/A customers are informed of this Safety Recall. A copy of the customer letter is reproduced on page 6 of this Service Bulletin.

DEALER INVENTORY

Some units affected by this Safety Recall may be in your inventory. **According to federal law, these units cannot be sold until they are repaired.** Refer to the INSPECTION/REPAIR PROCEDURE OVERVIEW section of this Service Bulletin.

CAMPAIGN VERIFICATION

Before you begin the inspection procedure, check if the inspection/repair has been performed on the unit. See the IDENTIFICATION section of this Service Bulletin for more details.

If there is a punch mark on the VIN plate as specified in this Service Bulletin, the unit has been inspected or repaired and no further action is required.

If there is no punch mark on the VIN plate as specified in this Service Bulletin, proceed to the INSPECTION PROCEDURE section of this Service Bulletin.

IMPORTANT: Due to the complexity of this campaign it is imperative that you check **iN** and your Dealer Responsibility Report **before** you begin repairs. If **iN** or your Dealer Responsibility Report indicate the Safety Recall has been performed, but you confirm the unit is not punched and the repair has actually been done (by inspecting the weld), please contact the Warranty HelpLine at (800) 421-1900, option 7.

INSPECTION PROCEDURE

IMPORTANT: During these procedures you may be using and referring to the following materials, originally sent to you with Service Bulletin GL1800 #14.

- 2002-2003 GL1800/A Frame Weld Safety Recall Dealer Procedures (S0510)
- Frame Weld Inspection Chart (S0516)
- 2002-2003 GL1800/A Frame Weld Safety Recall Welding Manual (S0511)
- 2002-2003 GL1800/A Frame Weld Safety Recall Cracked Weld Repair Manual (S0515)
- Welding Template Box (S0512)

If you need additional copies of these materials you may order them at no cost from Resolve at (440) 572-0725.

1. Position the motorcycle on a firm, level surface, in an area where there is enough room to safely lay it on its left side.
2. Remove the **left side mirror** by following the instructions on page 2-7 of the Service Manual.
3. Remove the **left engine side cover** by following the instructions on page 2-5 of the Service Manual.
4. Remove the **antenna whip(s)**.

5. Remove the **coolant reserve tank** by following the instructions on page 6-7 of the Service Manual.
6. Place thick, non-abrasive padding (such as furniture blankets) on the ground to protect the motorcycle when you lay it on its side.
7. **Lock the handlebars to the RIGHT**, using the ignition key.
8. **Using two people**, gently lay the motorcycle down on its **LEFT side on the padding**. The motorcycle will first rest on the wheels and left engine and saddlebag guards. Continue to lean the motorcycle to the left until it rests on the left handlebar end and left engine and saddlebag guards.

The motorcycle should be laying on the padding, with its engine guard, saddlebag guard, and handlebar end resting on the padding – no painted parts should be contacting the padding.

9. Clean the frame crossmember with acetone.
10. Draw a line on each side of the **grinding template** (S0512) 30 mm from the forward edge, stopping between the two arrows, as illustrated below.

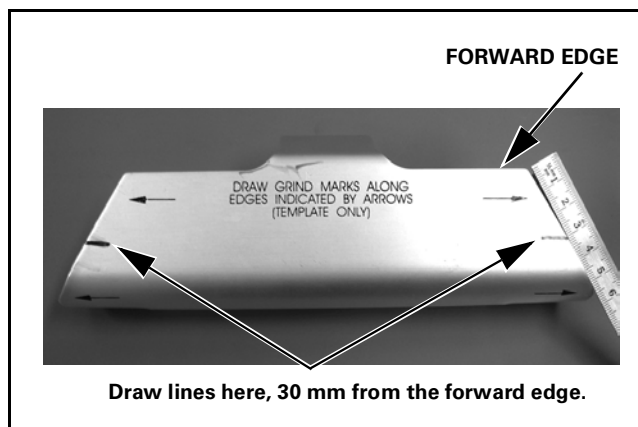

11. Put this template on the frame and, using a fine-tipped felt marker (such as a Sharpie), draw a **30 mm line** on both crossmember welds. Start this line at the **forward edge** of the grinding template and stop between the two arrows as shown in the illustration on the next page. Now remove the grinding template.

NEW

Draw 30 mm lines here.

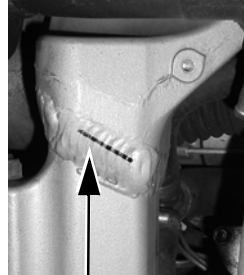
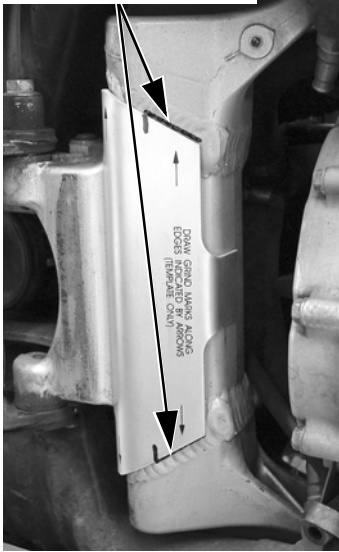

Lines DO NOT extend around corners.

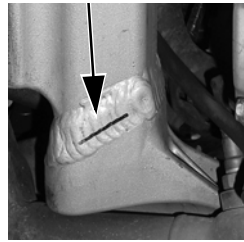

12. Inspect both Left and Right welds for any cracks. **If you do not find any cracks**, proceed to step 13 below. **If you find a crack**, perform the following procedure:

Place the **grinding template** (S0512) on the crossmember. Using a fine-tipped felt marker (such as a Sharpie), draw a line on the weld with the crack, drawing the line along the entire edge of the template (this line will be 89 mm long).

If the crack falls within the length of this line (89 mm), prepare the motorcycle for welding per the *Dealer Procedures* and advise the welder to use the *Cracked Weld Repair Manual* (S0515). After the bike has returned from the welder, prepare the frame and re-assemble the motorcycle per the *Dealer Procedures*. Then, proceed to the IDENTIFICATION section of this Service Bulletin.

If the crack exceeds the length of this line (89 mm), call TechLine at (800) 421-1900 for further instructions.

13. If no cracks were found, inspect the crossmember welds using the **Weld Inspection Tool** (S0517) and the following instructions:

- Start with the Right weld and then inspect the Left weld.

- Place the Weld Inspection Tool on the crossmember with the INBOARD side facing the center of the crossmember. The inboard edge of the tool should contact the crossmember at all times, with the arrow-marked tip touching the marker line.



- Move the tool along the full length of the marker line, at a right angle to the line. As you move the tool along the 30 mm line, the arrow-marked tip should contact the "peaks" of the weld. The tip does not need to make contact with the "valleys" of the weld beads.

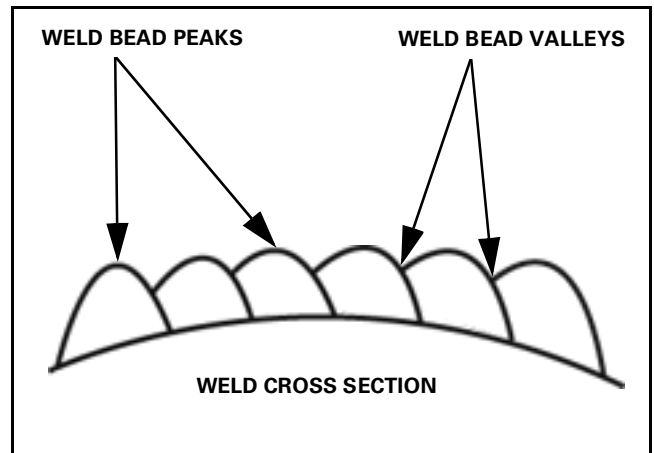

If the arrow-marked tip touches the weld bead "peaks" (top of each weld bead) along the entire length of the marker lines, the welds are GOOD (see illustration on the next page). Raise the motorcycle and reinstall all parts in the reverse order of removal. Proceed to the IDENTIFICATION section of this Service Bulletin.

NEW

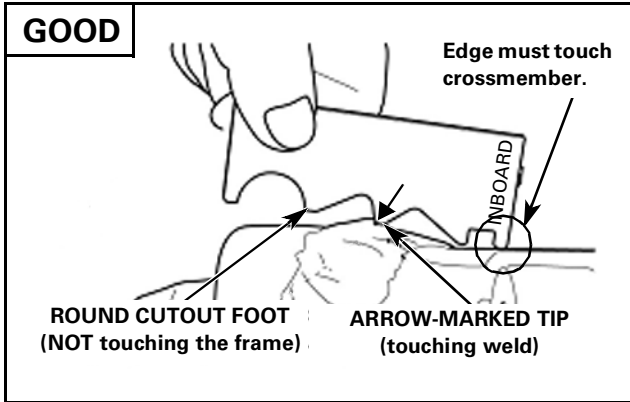

If the arrow-marked tip **DOES NOT** touch the weld bead peaks along the entire length of the marker line, the welds are NO GOOD (see the NO GOOD illustration).

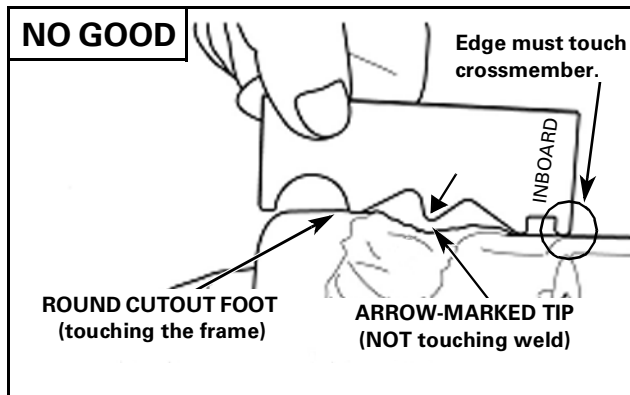

If your inspection indicates a NO GOOD weld **on either side**, you must weld **both** sides. Proceed to the REPAIR PROCEDURE section.

REPAIR PROCEDURE

IMPORTANT: For complete Dealer and Welder Repair procedures, refer to the following items:

- 2002-2003 GL1800/A Frame Weld Safety Recall Dealer Procedures (S0510)
- Frame Weld Inspection Chart (S0516)

You **MUST** provide your TIG welder with the following items:

- 2002-2003 GL1800/A Frame Weld Safety Recall Frame Welding Manual (S0511)
- Welding Template Box (S0512)

For your reference, a brief repair procedure overview is provided below.

DISASSEMBLY OVERVIEW

You will be removing the following components from the vehicle as instructed in the *Dealer Procedures*:

- Handlebar weights
- Rear view mirrors
- Swingarm pivot covers
- Rider foot pegs
- Seat
- Side covers/Engine side covers
- Fairing pockets
- Fairing molding
- Meter panel
- Top shelter
- Battery
- Fuel tank
- Main wiring harness ground
- Front lower fairing
- Front exhaust pipe protector
- Muffler/exhaust pipe
- Antenna Whip(s)
- Coolant reserve tank
- Centerstand

NOTE: You will need to remove any accessories that may contact the ground during the Welding and Re-assembly procedures.

IMPORTANT: You **MUST** cover the following with **RED duct tape** for welder identification purposes:

- Negative (-) and positive (+) battery cables
- Fuel return hose end
- Fuel feed hose end
- Main wiring harness ground
- Alternator
- Exhaust ports

WELDING OVERVIEW

A qualified TIG welder will weld the frame following the *2002-2003 GL1800/A Frame Weld Safety Recall Welding Manual* procedures.

RE-ASSEMBLY OVERVIEW

You will be inspecting the new TIG welds (see page 13 of the *Frame Welding Manual* and *Frame Weld Inspection Chart*), painting the frame, and re-assembling the vehicle as detailed in the re-assembly section of the *Dealer Procedures*.

IDENTIFICATION

If your inspection has determined both crossmember welds to be good, make a punch mark on the lower right hand corner of the VIN plate, as shown below.

If you needed to repair the crossmember welds, after you have completed the disassembly, welding, painting, and re-assembly procedures, make a punch mark on the lower right hand corner of the VIN plate, as shown below.

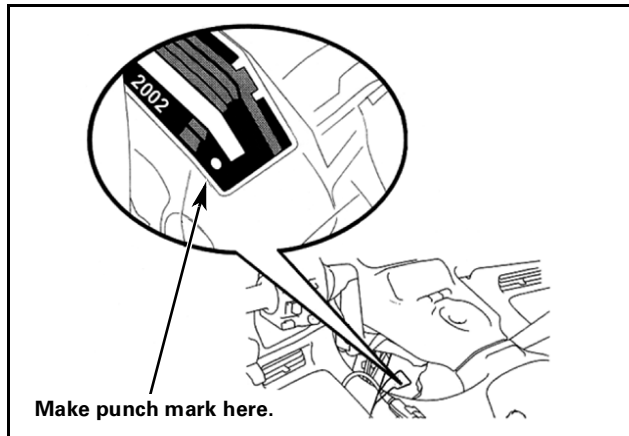

PARTS INFORMATION

These parts kits are currently available for open ordering.

Frame Parts Kit (Weld)

P/N: 18390-MCA-325

H/C: 7620982

This kit includes:

- Fiber washer (8)
- Exhaust gasket (6)
- Muffler packing (3)
- Shock linkage seal (2)
- Fuel feed hose O-ring (1)

NOTE: One kit is required for each vehicle.

WARRANTY INFORMATION

This Safety Recall will be in effect until all units have been repaired according to this Service Bulletin, regardless of the date of purchase.

Normal warranty claim submission requirements apply. After completion of the repair, submit one warranty claim per unit with the following information only:

NOTE: If TechLine has provided you with different claim filing instructions, please file your claim per those instructions. You should not file two claims.

WARRANTY CLAIM TEMPLATES:

GL1800/A Inspection and OK (no welding necessary)

Template: P66A

Flate Rate Time: 0.9 hours

GL1800/A Inspection and frame welding

Template: P66B

Flate Rate Time: 6.2 hours

(0.7 hours for inspection; 5.5 hours for disassembly, transport to and from welder, painting and re-assembly, removal and reinstallation of accessories).

Template P66B also includes reimbursement for Frame Parts Kit (18390-MCA-325) and \$2.00 materials reimbursement for paint.

Sublet for Welding:

Be sure to select the following on your template claim:

Sublet Involved – Yes

Sublet Description – Welding

Invoice Number – from invoice

Amount – from invoice

TEXT OF CUSTOMER LETTER

February 2005

IMPORTANT SAFETY RECALL NOTICE

Dear Gold Wing Owner:

This notice is sent to you in accordance with the requirements of the National Traffic and Motor Vehicle Safety Act.

What is the reason for this notice?

Honda Motor Co., Ltd. has decided that a defect relating to motor vehicle safety exists in certain 2001-2002 model year GL1800/A Gold Wing motorcycles. Certain frame welds may not have sufficient strength. High loads created when riding on rough road surfaces or through potholes can cause the affected welds to crack. In the worst case, the welded area could break without warning, resulting in lower cross member separation and rear suspension collapse. This could result in a crash.

What should you do?

Call any authorized Honda motorcycle dealer and make an appointment to have your frame inspected. The inspection procedure will determine whether the welds are sufficient. If the welding is not sufficient, the dealer will reinforce the welds according to a factory-prepared welding manual. The inspection and any necessary repairs will be done *free of charge*.

Who to contact if you experience problems.

If you are not satisfied with the service you receive from your Honda dealer, you may write to:

American Honda Motor Co., Inc.
Motorcycle Customer Support
Mail Stop 100-4W-5B
1919 Torrance Blvd.
Torrance, CA 90501-2746

If you believe that American Honda or the dealer has failed or is unable to remedy the defect in your motorcycle, without charge, within a reasonable period of time (60 days from the date you first contact the dealer for a repair appointment), you may submit a complaint to:

Administrator
National Highway Traffic Safety Administration
400 Seventh Street, SW
Washington, DC 20590

Or call the toll-free Safety Hotline at (888) 327-4236.

What to do if you feel this notice is in error.

Our records show that you are the current owner of a 2001-2002 GL1800/A involved in this recall. If this is not the case, or the name/address information is not correct, please fill out and return the enclosed, postage-paid *Information Change Card*. We will then update our records.

If you previously paid for a frame repair, you may be eligible for reimbursement. Please call Motorcycle Customer Support at (866) 784-1870 for assistance.

If you have questions.

If you have any questions about this notice, or need assistance with locating a Honda dealer, please call Motorcycle Customer Support. You may also visit our Web site at www.hondamotorcycle.com and click on "Locate a Dealer" to locate a Honda dealer who can assist you.

We apologize for any inconvenience this campaign may cause you.

Sincerely,
American Honda Motor Co., Inc.
Motorcycle Division