

1988 GL1500 LOW SPEED DRIVEABILITY IMPROVEMENT

(This supersedes GL1500 #2, dated June, 1988.)

Some 1988 GL1500s may experience a slight hesitation during light acceleration. This condition usually occurs just above idle speed.

A carburetor kit (containing slow jets, jet needles and vacuum pistons), ignition control unit and carburetor control unit are now available for improved low speed driveability on affected GL1500s.

In addition, correct routing of the carburetor hoses and vacuum lines is necessary to ensure proper engine performance. Other driveability symptoms, such as idle fluctuation and afterfire, may result if the hoses and lines are pinched, kinked or loose. **Pay special attention to the correct routing of the hoses/lines described and shown in this bulletin.**

APPLICABLE MOTORCYCLES

All 1988 GL1500s

REPAIR PROCEDURES

IMPORTANT NOTES:

- As part of PDI, test ride new GL1500s and check low speed engine performance. If the motorcycle has any of the symptoms noted above, perform the repairs described in this bulletin before release to your customers.
- The procedures that follow apply to both 49-State and California models.
- Carefully remove and install the plastic body parts and covers. Be sure ALL fasteners and tabs are removed or released first.
- Be sure ALL hoses are routed as shown or described to prevent pinching or kinking. A pinched, kinked or loose hose may cause other symptoms that could contribute to poor engine performance. (Also refer to Service Bulletin GL1500 #1 for carburetor vent hose routing and vacuum fuel valve installation.)
- If you need additional information, contact your CSR (1-213-512-6657) or American Honda's Tech Line (1-800-421-1900).

1. Remove the following parts; refer to the 1988 Service Manual for details.

- Seat (13-8)
- Left and right rear side covers (13-8)
- Left and right front side covers (13-8)
- Both fairing pockets (13-8, 9)
- Ignition switch cover (13-9)
- Top inner covers (13-9)
- Top compartment (13-9)
- Fairing front cover (13-10)
- Fairing inner covers (13-11)
- Air cleaner case (4-17) NOTE: Disconnect the four hoses from the bottom of the case.

2. Disconnect the fuel line from the 3-way fitting.

⚠ WARNING Gasoline is extremely flammable and is explosive under certain conditions. Do not smoke or allow flames or sparks in your work area.

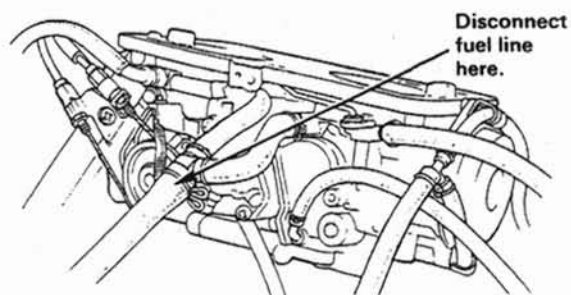

3. Disconnect the #16 and #17 hoses from the Air Jet Controller (AJC), located in the right fairing pocket.

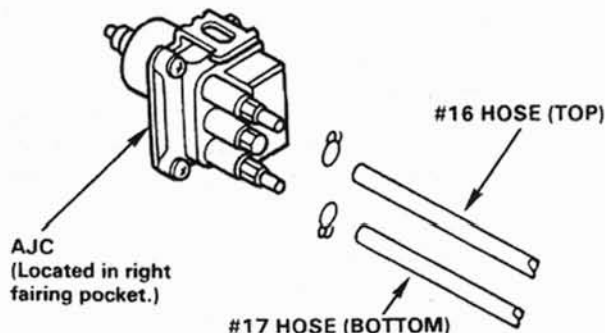

ROUTING:

COPY 1

GENERAL MANAGER

SALES DEPT.

OFFICE FILE

COPY 2

SERVICE MANAGER

MECHANICS

SHOP MANUAL

4. Disconnect the #18 and #19 hoses from the Air Jet Solenoid Valves.

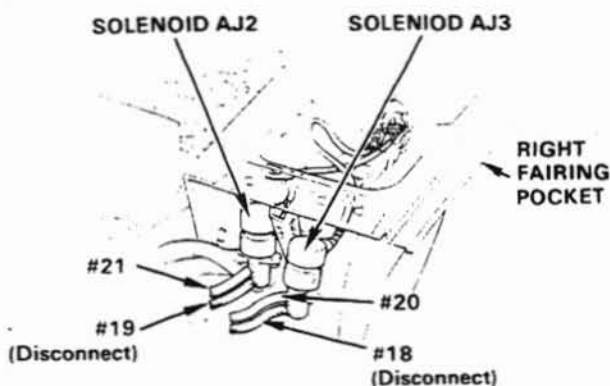

5. CALIFORNIA MODELS ONLY: Disconnect the #5 and #11 hoses from the Purge Control Valve (PCV).
6. Remove the idle adjuster knob from its holder in the fuel filler tray. Then disconnect the blue 2-pin cruise control cancel switch connector, located in the stack of connectors on the left side near the gas tank.
7. Remove the carburetor assembly; refer to the Service Manual, pages 4-18, 4-19.

- Loosen the radiator cap to relieve pressure from the system. Then re-tighten the cap.
- Loosen the insulator bands (upper side, near carburetor) and remove carburetors from insulators.
- Lift front side of carburetor assembly and disconnect the two water hoses.
- Remove the choke cable.
- Remove the throttle cables by removing the two screws that secure the cable stay (bracket). It is not necessary to remove the cables from the stay.
- Cover the intake manifold with clean shop towels to prevent loose parts from falling into the engine.

8. Place the carburetor assembly on a work bench and drain the float bowls into a suitable container. Then re-tighten the drain screws.

!WARNING Gasoline is extremely flammable and is explosive under certain conditions. Do not smoke or allow flames or sparks in your work area.

9. Remove the heat riser and air horn assembly. Then remove the two screws that hold the accelerator pump body to the right carburetor — keep the two dowel pins and the O-ring on the float bowl.

NOTE: Do not remove the throttle linkage; it can stay connected between the two carburetors. Refer to pages 4-20 through 4-22 in the Service Manual.

10. Remove the float bowl and the slow jet from each carburetor. Install the new slow jets (#55) supplied in the kit. Check the position of the float arm pin; it should be positioned evenly in both mounts.
11. Without removing the limiter caps, turn each pilot screw IN (clockwise) 1-1/8 turn. Install the float bowls and tighten the screws securely.
12. Attach the accelerator pump body on the right carburetor. Be sure the two dowel pins and O-ring are installed.
13. Align the pilot screw limiter caps against the float bowl stoppers by turning them 1/8 turn OUT (counterclockwise).
14. Install the heat riser and air horn assembly.
15. Remove the vacuum chamber covers, springs, and vacuum pistons.
16. Install the new vacuum pistons (supplied in the kit) following the detailed procedure described in the October, 1986 issue of THE WRENCH (also see page 4-29 in the GL1500 Service Manual). This will ensure that the vacuum chambers are sealed correctly.
17. Remove and replace the Ignition Control Unit (ICU). Be sure the #3, #4, and #5 hoses are NOT pinched and are routed as shown.

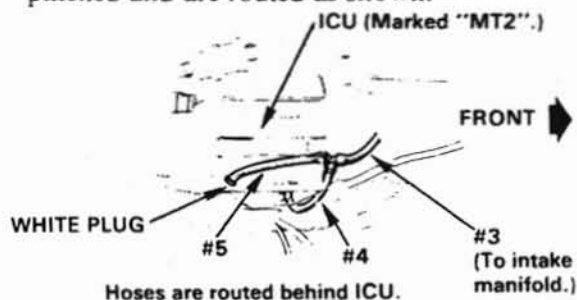

NOTE: The new ICU is marked "MT2" for future identification.

18. Remove the two screws and the Carburetor Control Unit (CCU) and bracket. Install the new CCU into the bracket and attach it to the fairing with the two screws.

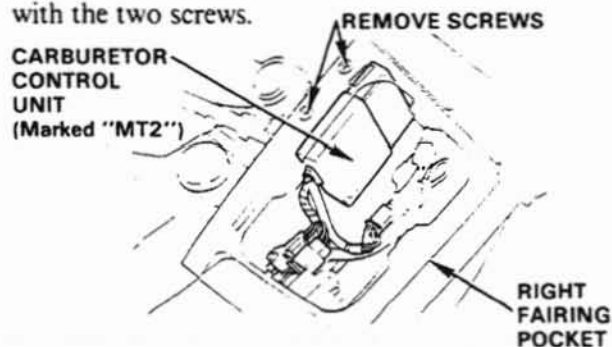

NOTE: The new CCU is marked "MT2" for future identification.

19. Locate the 3-way joint (49-State) or 4-way joint (Calif.) on the right side of the engine above the spark plugs. Check the valve body for cracks or air leaks and replace it if necessary. Be sure the hoses are pushed completely onto the valve.

NOTE: A leaking valve could affect driveability performance.

20. Locate Water Hose "A" on the left side of the engine, coming down from the intake manifold. The hose must not be pinched or kinked.

- If necessary, rotate the hose and/or trim off about 5 mm to correct the routing. To gain access to the hose, remove the left cooling fan.

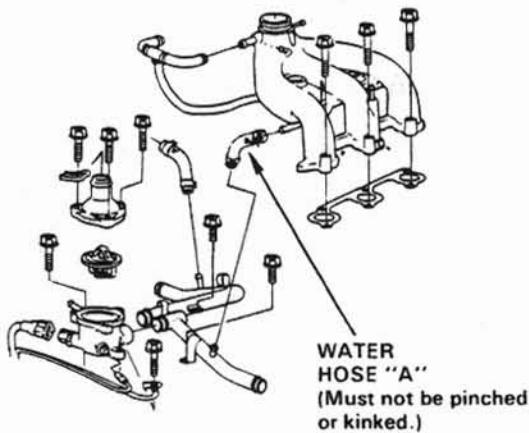

IMPORTANT NOTE: If this hose is pinched or kinked, cold weather driveability could be affected.

21. Check that the Deceleration Compensation Hose #8 is NOT pinched or kinked: route the hose as shown.

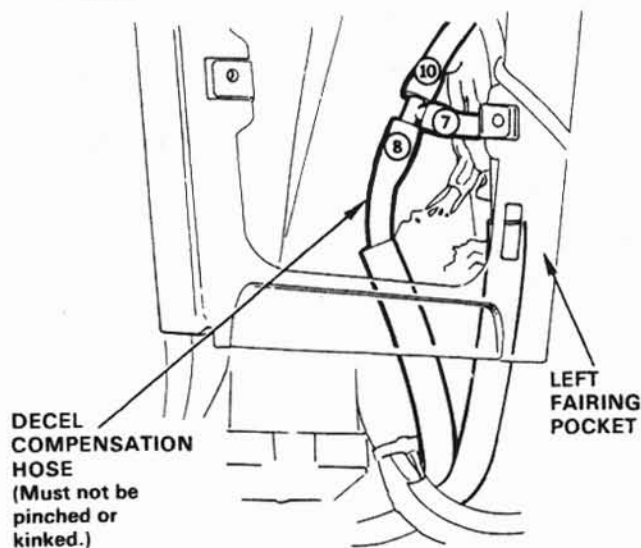

NOTE: The optional CB radio is mounted in this area — be sure the CB wire harness does not pinch or kink the hose.

22. Check the carburetor choke valve (plunger) for smooth operation from the fully closed to the fully open position. Then check that the idle adjuster is threaded into the carburetor and the knob operates smoothly.

23. Install the carburetor assembly onto the engine. Pay special attention to the following:

- Connect the carburetor drain tube to the 3-way joint.
- Connect the two front water hoses.
- Install the choke and throttle cables. Check the free play and adjust if necessary.
- Connect and tighten the insulator bands.
- Attach the fuel line to the 3-way fitting.
- Connect the blue 2-pin cruise control cancel switch connector.
- Position the idle adjuster knob in its holder in the fuel tray.
- CALIFORNIA MODELS ONLY: Connect #5 and #11 hoses to the Purge Control Valve.

24. Connect #16 (top) and #17 (bottom) hoses to the Air Jet Controller. Then connect #18 (right) and #19 (left) Air Jet Solenoid Valve hoses.

25. Check the Secondary Throttle Cable for free play and adjust if necessary according to the Service Manual, page 4-77.

26. Confirm the routing of all the hoses as shown below. Be sure none of the hoses are pinched, kinked or loose. For reference, see pages 4-33, 34 in the Service Manual.

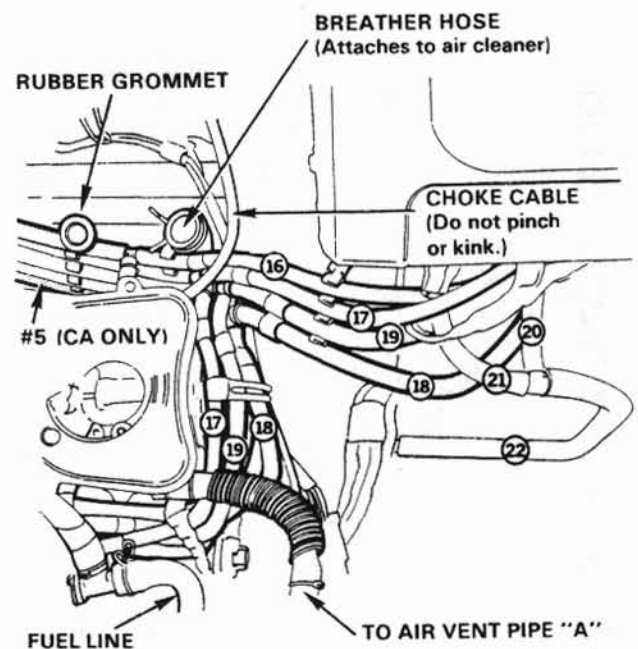

49 STATE MODEL SHOWN

27. Start the engine and check the following:

- Accelerator pump operation
- Carburetor slide operation
- Fuel and water leaks
- Choke and throttle cable operation in all steering positions

28. Carefully install the air cleaner case onto the carburetors and attach the hoses to it. Install the air cleaner element and the case cover.

IMPORTANT: Be sure the carburetor hoses and choke cable are not pinched or kinked by the air cleaner case.

29. For future identification, punch an "X" mark on the right frame section as shown. This will identify 1988 GL1500s that have the new parts installed.

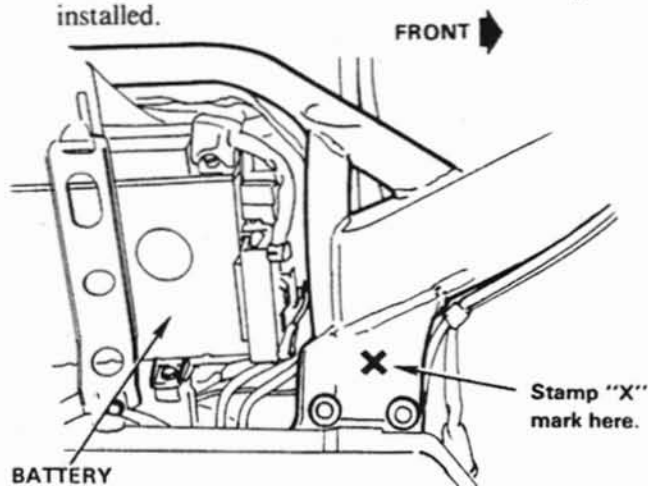

30. Carefully install the removed body parts in the reverse order of disassembly.

31. Route the two breather hoses as shown — cut the hoses so they extend 40 mm past the bracket. The gasoline overflow tube should extend 5 mm below the lower holding bracket.

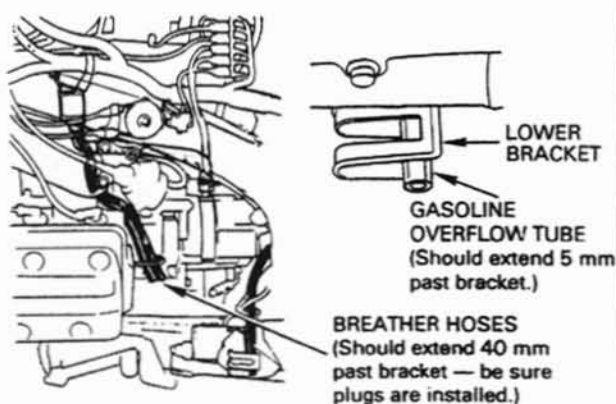

NOTE: The hoses must be properly routed to prevent damaging them. Be sure the plugs are installed into the breather hoses to keep dirt from being drawn into the air cleaner.

PARTS INFORMATION

- Carburetor Kit (1 required)
P/N: 16020-MN5-315
H/C: 2979771

Includes the following:

- Slow jets, #55 (2)
- Vacuum pistons (2)
(includes new jet needle)

- Ignition Control Unit (1 required)
P/N: 30410-MT2-003
H/C: 2979433
- Carburetor Control Unit (1 required)
P/N: 30430-MT2-003
H/C: 2979425

WARRANTY INFORMATION

The normal warranty policies and procedures apply. If you feel goodwill consideration is appropriate, contact SWAT (see pages 3-3, 3-4 in the Warranty Policy and Procedure Manual) before starting the repair.

The following claim preparation information is exclusive to this service bulletin. Do not use this information on any other repair.

- For CARBURETOR KIT, ICU and CCU installation, submit a claim form with the following information:

Contention Code: J2Ø
Defect Code: 367
Failed Honda Code: 2820231
Labor Operation Number: 311190
Flat Rate Time: 3.8 hours

- For CARBURETOR KIT, ICU, CCU and WATER HOSE "A" (step 20) repair, submit a claim form with the following information:

Contention Code: J2Ø
Defect Code: 367
Failed Honda Code: 2820231
Labor Operation Number: 311195
Flat Rate Time: 4.2 hours