



# SERVICE BULLETIN

AMERICAN HONDA MOTOR CO., INC. MOTORCYCLE SERVICE DEPARTMENT

## PRODUCT UPDATE 1988 GL1500 CARBURETOR VENT HOSE ROUTING

(This Product Update supersedes GL1500 #1, dated February, 1988.  
Follow the update procedures in this bulletin and discard the original GL1500 #1.)

American Honda is conducting a Product Update Program on 1988 GL1500s to install a carburetor vent hose kit. The addition of this kit is necessary to ensure that the vent hoses are properly routed and not pinched or kinked.

If the vent hoses are pinched or kinked, fuel could overflow into the cylinders while the engine is off. If this happens, the starter motor may not be able to turn over the engine.

The update kit contains a metal air vent pipe and a vacuum fuel valve. The vent pipe will ensure correct routing of the hoses to prevent pinching or kinking. Additionally, the new vacuum fuel valve will stop fuel from flowing to the carburetors when the engine is turned off.

The update kit must be installed on any applicable 1988 GL1500 (see below) by following the procedures described in this bulletin.

### APPLICABLE GL1500s

- 49-State Models:
  - Up to VIN 1HFSC2200JA004107
- California Models:
  - Up to VIN 1HFSC2218JA000959

NOTE: Some of these units may have already been updated. All new GL1500s after the above VIN's have been updated by the factory.

Updated units can be identified by opening the fuel filler compartment. If the new air vent pipe and vacuum fuel valve are installed, the Product Update has already been completed.

### DEALER INVENTORY OF GL1500s

Any new 1988 GL1500 in your inventory within the applicable VIN shown must be updated before release to the customer.

### CUSTOMER-OWNED GL1500s

Applicable customer-owned GL1500s must also be

updated with the new parts.

American Honda will send a letter to all 1988 GL1500 owners informing them that they are entitled to receive this update without charge. They will be instructed to call and make an appointment for the update work. For your reference, the text of the customer letter is reproduced on page 5 of this bulletin.

This Product Update Program will end on August 31, 1988.

### UPDATE REPAIR PROCEDURE

#### IMPORTANT NOTES:

- The procedures that follow apply to *both* 49-State and California models — individual differences are noted.
- Be sure ALL hoses are routed as shown or described to prevent pinching or kinking. Clips should be attached on all hoses.
- **Carefully** remove and install the plastic body parts and covers. *Be sure ALL fasteners and tabs are removed first.*
- Use the 1988 GL1500 Service Manual for parts reference and location.
- If you need additional information, contact your CSR (1-213-512-6657) or American Honda's Tech Line (1-800-421-1900).

1. *Carefully* remove the following parts; refer to section 13 of the GL1500 Service Manual for details.

NOTE: Before removing these parts, be sure ALL fasteners and tabs are released.

- Seat (13-8)
- Left and right side covers (13-8)
- Both fairing pockets (13-8, 9)
- Ignition switch cover (13-9)
- Top inner covers (13-9)
- Top compartment (13-9)
- Fairing front cover (13-10)
- Fairing inner covers (13-11)

goldwingdocs.com

#### ROUTING:

COPY 1  
COPY 2

- |  |                                      |                                      |
|--|--------------------------------------|--------------------------------------|
| <input type="checkbox"/> GENERAL MANAGER | <input type="checkbox"/> SALES DEPT. | <input type="checkbox"/> OFFICE FILE |
| <input type="checkbox"/> SERVICE MANAGER | <input type="checkbox"/> MECHANICS   | <input type="checkbox"/>             |

2. Locate the right and left carburetor vent hoses that connect into a T-fitting at the back of the air cleaner box. Measure and cut these hoses as follows:

— Remove both hoses from the T-fitting. Discard the fitting.

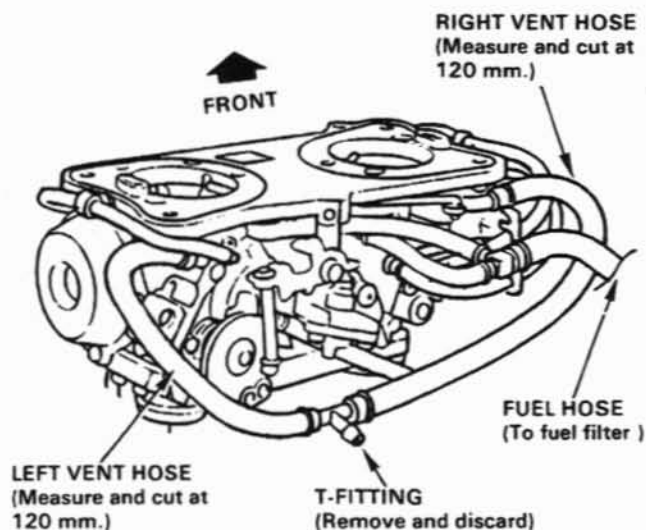

— Left and Right Hose: Measure back 120 mm from the carburetor and cut both hoses at this point. Discard the cut hose pieces.

**IMPORTANT:** Be sure the length of each hose is 120 mm.

3. Remove the fuel hose from the carburetor side of the fuel filter. Measure and cut 30 mm off this hose.

**⚠ WARNING** Gasoline is extremely flammable and is explosive under certain conditions. Do not smoke or allow flames or sparks in your work area.

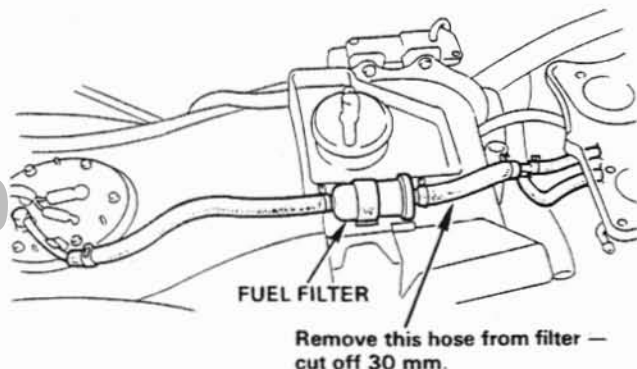

4. Remove the fuel filter and idle speed knob from their mounting tabs (holders) on the fuel filler tray.
5. Remove the gas cap and cover the fuel filler opening with a clean shop towel to prevent loose parts from falling into the fuel tank. Disconnect the fuel overflow hose from the filler tray.

6. **CALIFORNIA MODELS ONLY:** Pull off the small vacuum hose from the Air Vent Control Valve (AVCV). Remove the AVCV from its mounting tab on the fuel filler tray.

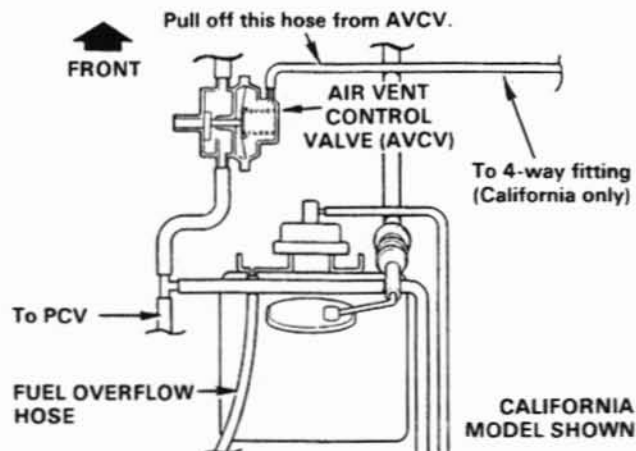

7. Lift up the fuel filler tray and install the gas cap. Using needle nose pliers from underneath the tray, gently squeeze the plastic tabs on the idle speed knob holder. Remove the holder from the tray.
8. Push the holder into the bracket on the new vacuum fuel valve provided in the kit. Mount the valve on the fuel filler tray using the screw/washer supplied. (The screw threads into the bracket from underneath the tray — use the hole where the idle speed knob holder was originally installed.)
9. Remove the gas cap and position the tray over the fuel filler opening. Reinstall the gas cap and the fuel overflow hose. Place the idle speed knob in its holder.
10. Insert the new 90° elbow provided in the kit into the carburetor fuel hose. Push the other end of the hose on the rear fitting of the vacuum fuel valve. Position and secure the hose clips.

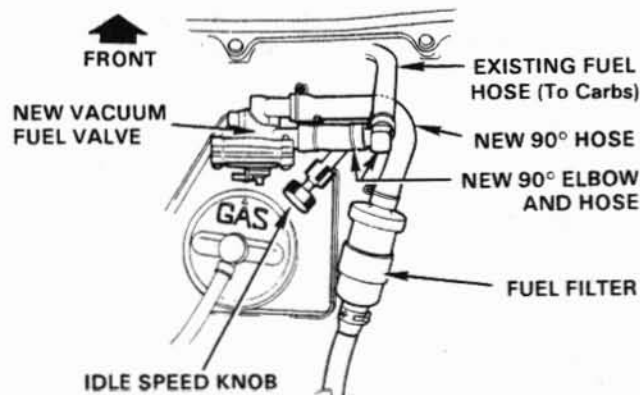

11. Install the new 90° fuel hose onto the fuel filter and attach the filter back onto its mounting tab. Connect the other end of the hose to the front fitting on the vacuum fuel valve. Position and secure the hose clips.

**NOTE:** The large end of the hose should be installed on the fuel valve.

12. Slide the new spring over the right vent hose. Push both the vent hoses onto the new Air Vent Pipe "A" (push on 20 mm to the stopper). Remove the two rear air cleaner cover screws and mount the new vent pipe onto the air cleaner box.

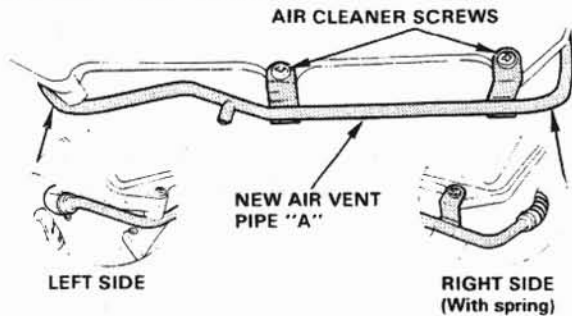

- Check that both vent hoses are not pinched or kinked, especially where they bend around the air box.

13. **49-STATE MODELS ONLY:** Remove the vacuum hose from the fitting on the right intake manifold, between #3 and #5 spark plug.

NOTE: For future carb. synth., remove this hose and connect vacuum gauge to T-fitting.

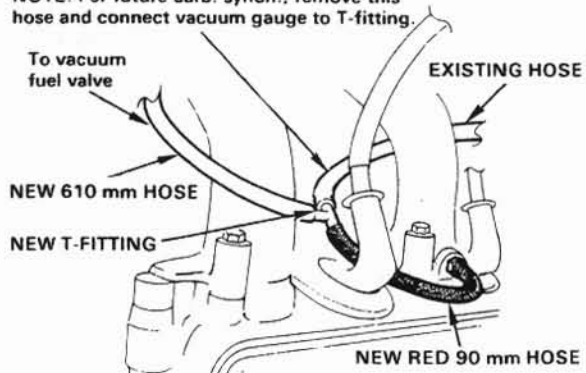

- Measure, cut and discard 100 mm from the end of this hose. Install the new T-fitting into this hose and attach the red vacuum hose back onto the manifold fitting. Position and secure the hose clips.

#### CARBURETOR SYNCHRONIZATION

NOTE: The new vacuum fuel valve needs to remain connected for the bike to run. For future carburetor synchronization, leave the 610 mm hose and the red vacuum hose connected. Disconnect the remaining cruise control vacuum hose and attach the vacuum gauge at this fitting. (This does not apply to California models)

- Attach the new 610 mm vacuum hose to the center of the new T-fitting. Route this hose up inside the frame between the air cleaner box and the front of the fuel tank. Connect the end to the fitting on the vacuum fuel valve. Be sure the hose is not pinched or kinked. Position and secure the hose clips.
- GO TO STEP 20.

#### CALIFORNIA MODELS ONLY (Steps 14 - 19):

14. Remove the Evaporative Emission Control Hose from the existing T-fitting — discard the fitting. Measure, cut and discard 165 mm from the end of this hose.

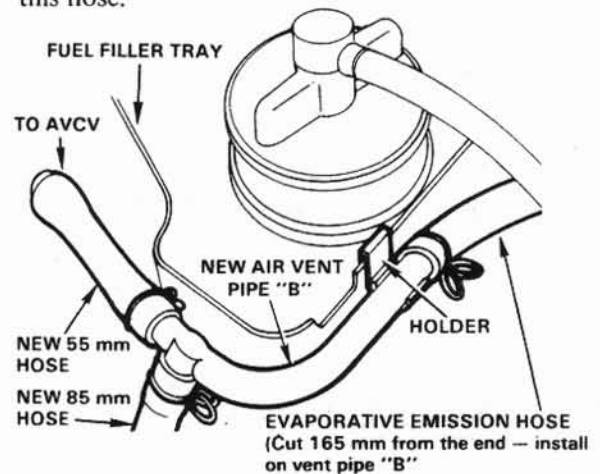

15. Install the new Air Vent Pipe "B" (with new hoses) in place of the original T-fitting and hoses. The vent pipe holder attaches on the lip of the fuel filler tray.

16. Measure, cut and discard 70 mm from the vacuum hose removed in step 6. Install the new T-fitting into this hose and connect the new 70 mm vacuum hose to the AVCV.

17. Attach the new 130 mm vacuum hose from the T-fitting to the vacuum fuel valve. Position the fuel valve hose clip downward.

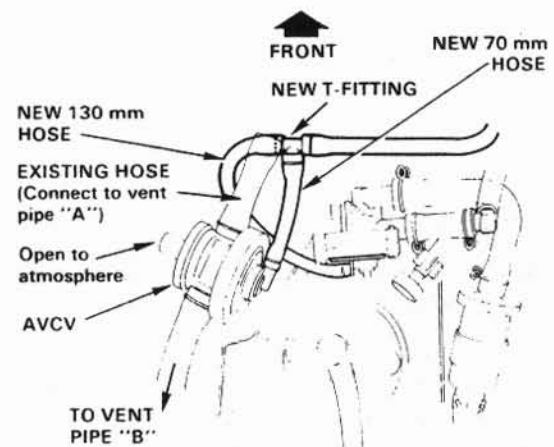

18. Route the new T-fitting and vacuum hoses **under** Air Vent Pipe "A". Connect the existing AVCV hose to Air Vent Pipe "A". Mount the AVCV on its tab on the fuel filler tray.

19. Check the Evaporative Emission Control Hose and fuel cap vent hose routing to the canister, making sure the hoses are not pinched or kinked. Affix the supplied Vacuum Hose Routing Diagram over the original one on the fuel tank.

goldwingdocs.com

**ALL UNITS (Steps 20 - 24)**

20. Confirm the installation and routing of all the new parts. Be sure the hoses are not pinched or kinked. Double-check that all hose clips are positioned and secured.

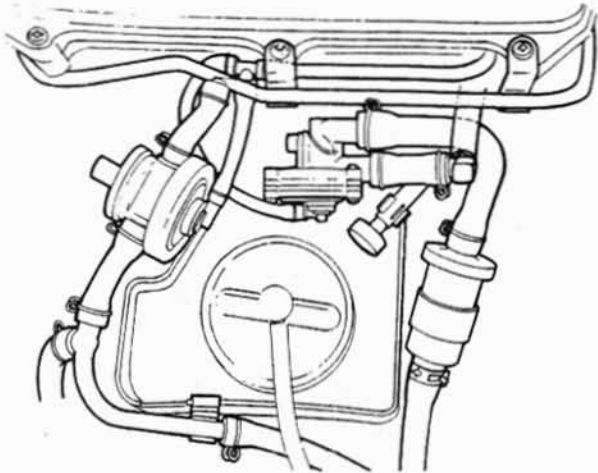

CALIFORNIA MODEL

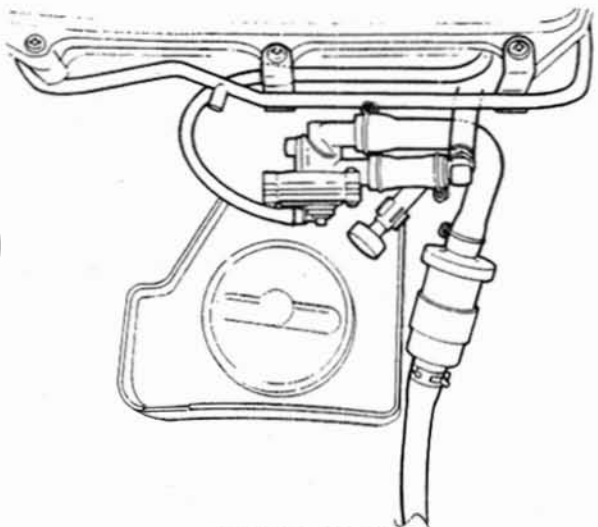

49-STATE MODEL

**Important Note:**

Be sure to perform the procedure for clearing the cylinders that follows:

21. A certain amount of fuel may "squirt" from the cylinders during this procedure. Move the motorcycle outside, away from anything you don't want fuel on.

**WARNING**

- Gasoline is extremely flammable and is explosive under certain conditions. Do not smoke or allow flames or sparks in your work area.
- The proper use of adequate safety equipment such as gloves, eye protection, safety shoes, and protective clothing can reduce the possibility of serious injury to yourself and others.

- A. Remove all six spark plugs.
- B. Lay several shop towels over the spark plug holes on each bank of cylinders. This will absorb any fuel that might be expelled from the cylinders.
- C. Move the engine stop switch to the "OFF" position.

**Important Note:**

Do not attempt to crank the engine over unless the engine stop switch is in the "OFF" position.

D. Turn the ignition switch "ON" and, with the throttle closed, crank the engine. This will clear any residual fuel from the cylinders. Allow the engine to spin for several seconds.

E. Install the spark plugs and plug wires.

22. Move the engine stop switch to the "ON" position. Start the engine and check that there are no fuel or vacuum leaks.

23. Position the top compartment on a padded surface on your workbench so the radio is face down. Using needle nose pliers, remove the radio cover latch spring. Remove (and discard) the latch from its mounting boss with needle nose pliers; twist and pull it out from the pivot points.

24. Install the new latch (provided in the kit) by aligning the pivot pins into the mounting boss holes; the latch should lock into position. Then, reinstall the latch spring and check that the latch pivots freely. Affix the new rubber pad to the corner of the radio/cassette as shown.

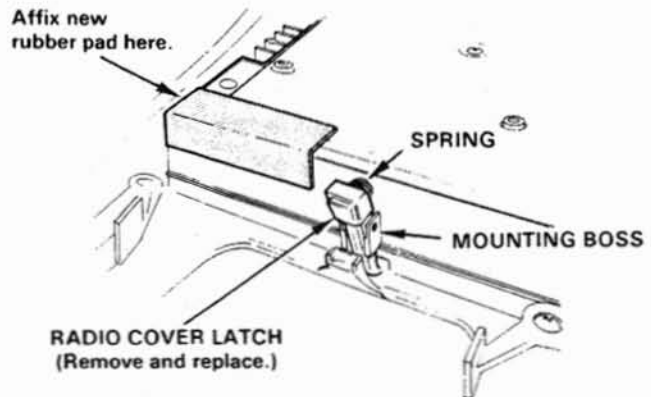

NOTE: The new latch is shaped different to clear the vacuum fuel valve with the top compartment installed. The rubber pad protects the fuel hose from rubbing on the radio housing.

25. Carefully install the removed body parts in the reverse order of disassembly.

NOTE: Be sure the body parts do not pinch or kink any of the hoses.

goldwingdocs.com

## IDENTIFICATION

For future reference, the new vacuum fuel valve and air vent pipe(s) will identify 1988 GL1500s that have been updated.

## PARTS INFORMATION

**IMPORTANT:** You will automatically be shipped 1 kit initially. Subsequently, you will be shipped the appropriate number of kits based on the number of units invoiced to your dealership.

There are two update kits — 49-State and California. The parts are not initially available for open ordering; for *future* ordering reference, the update kits are listed below.

- **49-State Kit**  
P/N: 06160-MN5-000  
H/C: 2941862

Includes the following:

- Vacuum fuel valve (1)
- Air vent pipe "A" (1)
- 90° elbow, with fuel hose (1)
- 90° fuel hose (1)
- T-fitting, with red 90 mm vacuum hose (1)
- Vacuum hose, 610 mm (1)
- Screw/washer (1)
- Radio cover latch (1)
- Radio rubber pad (1)
- Assorted clips
- Right vent hose spring (1)

- **California Kit**  
P/N: 06160-MN5-740  
H/C: 2941870

Includes the following:

- Vacuum fuel valve (1)
- Air vent pipe "A" (1)
- Air vent pipe "B", with 55 mm and 85 mm hoses (1)
- 90° elbow, with fuel hose (1)
- 90° fuel hose (1)
- T-fitting, with 70 mm and 130 mm vacuum hoses (1)
- Screw/washer (1)
- Radio cover latch (1)
- Radio rubber pad (1)
- Assorted clips
- Right vent hose spring (1)
- Vacuum hose routing diagram (1)

## WARRANTY INFORMATION

This Product Update Program will end on August 31, 1988. Claims submitted after this date will not be processed.

Submit a claim form with the following information:

- For 49-STATE and CALIFORNIA models:

**Contention Code:** J11  
**Defect Code:** 363  
**Failed Honda Code:** 2829513  
**Labor Operation Number:** 314804  
**Flat Rate Time:** 1.5 hours

## TEXT OF CUSTOMER LETTER

March 1988

Dear 1988 GL1500 GOLD WING Owner:

RE: PRODUCT UPDATE — Carburetor Vent Hose Routing

As an owner of the most prestigious touring motorcycle available today, American Honda realizes you are one of our most valued customers. To ensure your continued satisfaction, we are conducting a Product Update Program on 1988 GL1500 motorcycles to install a carburetor vent hose kit. The addition of this kit is necessary to ensure that the vent hoses are properly routed and not pinched or kinked.

Pinched or kinked vent hoses may cause fuel to overflow into the cylinders while the engine is off. If this happens, you may not be able to start the engine. The update kit contains parts that will correctly route the hoses to prevent pinching or kinking. Additionally, a new vacuum fuel valve is included to prevent fuel from flowing to the carburetors with the engine off.

Your authorized Honda motorcycle dealer will update your 1988 GL1500 by installing the new vent hose kit at no charge to you for parts or labor. We suggest you call the dealer that you purchased your Gold Wing from and make an appointment to have the update work performed. He will have the update kit for your motorcycle. You should plan on leaving your motorcycle at the dealership for at least half a day.

This Product Update Program will end on August 31, 1988. However, with good riding weather just around the corner, we recommend that you have the update performed on your Gold Wing as soon as possible.

If you have additional questions after discussing this update with your Honda motorcycle dealer, please contact the Motorcycle Customer Service Department in Gardena, California at 1-213-532-9811.

Good riding — and thank you again for buying a new Honda Gold Wing.

Sincerely,

AMERICAN HONDA MOTOR CO., INC.